

Self-Propelled Scissor Lifts

GS™ -2646

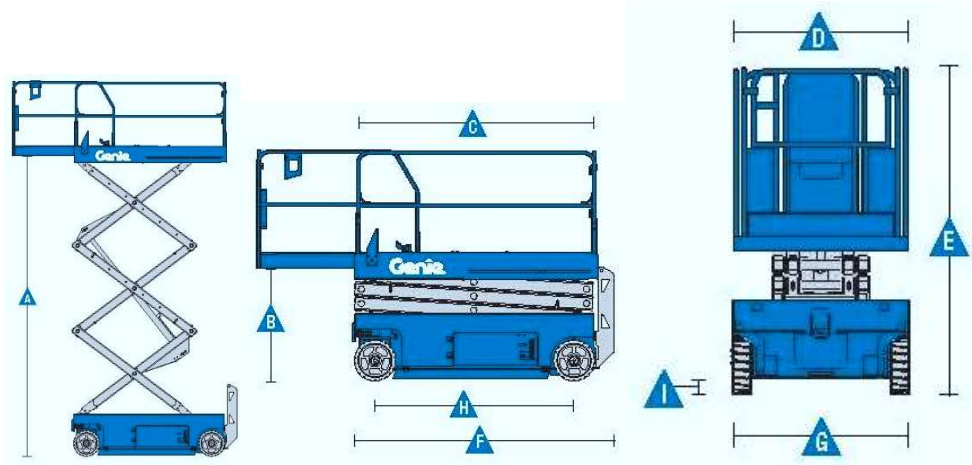

Brand	Genie
Model	GS-2646
Working height maximum - indoor	9.96 m
- outdoor	7.99 m
A Platform height maximum - indoor	7.96 m
- outdoor	5.99 m
B Platform height stowed	1.18 m
C Platform length - outside	2.26 m
Extended	3.18 m
Roll-out platform extension deck	0.91 m
D Platform width - outside	1.16 m
Guardrail height	1.1 m
Toeboard height	15 cm
E Height-stowed: folding rails	2.3 m
rails folded	1.68 m
F Length-stowed	2.44 m
Length-stowed extended	3.33 m
G Width	1.16 m
H Wheelbase	1.85 m
I Ground clearance-center	10 cm
- with pothole guards deployed	2.0 cm

Power	
Power source	24 V DC (four 6 V 225 Ah batteries)
Hydraulic system capacity	17.0 L

Productivity	
Maximum platform occupancy (in/out)	2/1
Lift capacity	454 kg
Lift capacity - extension deck	113 kg
Drive height	full height
Drive speed - stowed	3.2 km/h
Drive speed - raised	0.8 km/h
Gradeability - stowed	30%
Turning radius - inside	Zero
Turning radius - outside	2.29 m
Raise / lower speed	28 / 28 sec
Tilt sensor activation - front to back	3°
- side to side	1.5°
Controls	proportional
Drive	dual front wheel
Multiple disc brakes	dual rear wheel
Tires - solid non-marking	38 x 13 cm

Weight / Floor Loading	
Weight - ANSI, CSA	2,188 kg
Tire load, maximum	937 kg
Tire contact pressure	935 kPa
Occupied floor pressure	9.83 kPa