

Compact Excavator TB250



Brand	Takeuchi
Model	TB250
OPERATING PERFORMANCE	
Operating Weight - Cab	4,965 kg
Operating Weight - Canopy	4,825 kg
Bucket Capacity (Heaped)	0.141 m ³
Slew Speed	9.8 min-1
Travel Speed 1st / 2nd	2.8 km/h / 5.2 km/h
Gradeability	30°
Ground Pressure - Cab	28.1 kPa
Ground Pressure - Canopy	27.3 kPa
Maximum Bucket Breakout Force	37.2 kN
Maximum Arm Digging Force	25.9 kN
Traction Force	56.1 kN
Boom Swing Angle (Left/Right)	75° / 60°

ENGINE	
Model	Yanmar / 4TNV88
Rated Output (ISO 14396)	29.5 kW / 2,400 min-1
Maximum Torque	143.4 Nm / 1,440 min-1
Displacement	2,190 ml
Alternator	12 V - 0.48 kW
Battery (IEC 60095-1)	12 V - 115 A. h
FLUID CAPACITY	
Engine Lubrication	7.4 L
Cooling System	12.4 L
Fuel Tank Capacity	74.0 L
Hydraulic Reservoir Capacity	52.0 L
Hydraulic System Capacity	88.0 L

SAFETY and HEALTH			
Vibration Levels		Noise Level	
Hand / Arm	< 2.5 m/s ²	Sound Power Level	LWA 96 dB
Body	< 0.5 m/s ²		

HYDRAULIC SYSTEM						
P1, P2	Flow Rate	Variable Displacement Pump	58.3 L/min	Service Port 1	Flow Rate	58.0 L/min
	Relief Pressure		21.0 MPa		Flow Rate - High Flow	97.0 L/min
P3	Flow Rate	Gear Pump	38.9 L/min	Service Port 2	Flow Rate	39.0 L/min
	Relief Pressure		19.6 MPa		Hydraulic Pressure	19.6 MPa
				Service Port 3	Hydraulic Pressure	19.6 MPa

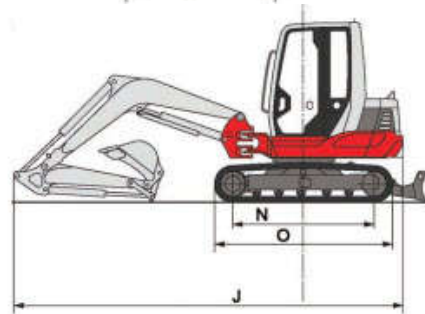
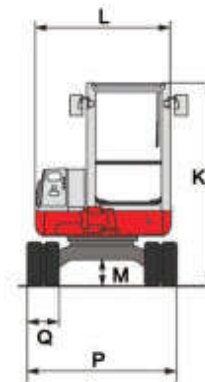
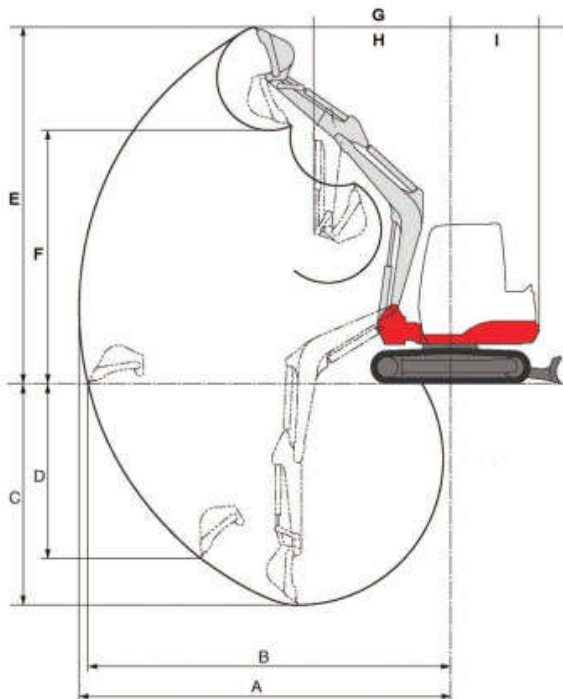

MACHINE DIMENSIONS		1,450 mm ARM	1,600 mm ARM	1,760 mm ARM
A	Maximum Reach	5,850 mm	5,990 mm	6,135 mm
B	Maximum Reach at Ground Level	5,705 mm	5,850 mm	5,995 mm
C	Maximum Digging Depth	3,475 mm	3,625 mm	3,785 mm
D	Maximum Vertical Digging Depth	2,725 mm	2,860 mm	2,990 mm
E	Maximum Height of Cutting Edge	5,625 mm	5,715 mm	5,800 mm
F	Maximum Dumping Height	3,990 mm	4,085 mm	4,175 mm
G	Front Swing Radius	2,170 mm	2,195 mm	2,235 mm
H	Front Swing Radius with Boom Offset	1,705 mm	1,730 mm	1,765 mm
I	Slew Radius	1,435 mm	1,435 mm	1,435 mm
J	Overall Length	5,470 mm	5,510 mm	5,550 mm
K	Overall Height	2,515 mm	2,515 mm	2,515 mm
L	Upper Structure Overall Width	1,690 mm	1,690 mm	1,690 mm
M	Ground Clearance	335 mm	335 mm	335 mm
N	Crawler Base	1,985 mm	1,985 mm	1,985 mm
O	Crawler Overall Length	2,500 mm	2,500 mm	2,500 mm
P	Crawler Overall Width	1,840 mm	1,840 mm	1,840 mm
Q	Crawler Shoe Width	400 mm	400 mm	400 mm